

BROASTER[®]
EQUIPMENT

Broaster[®] Pressure Fryer - 1600



Standard Features

- *Fast and productive* – specifically designed for high volume production, cooks up to 20 pieces of fresh bone-in chicken per load in as little as 10 minutes*.
- *Unique Pressure Activated Cover Locking Mechanism* – quick closing and opening single action sealing including a pressure-activated cover locking mechanism for safety and ease of use.
- *Proven round cooking well design* – engineered for more uniform heat distribution, durability, and efficiency; no cold spots or corners. Large capacity provides more room for product, minimizes sticking, and produces delicious, superior quality food.
- *Fully Welded Cooking Well* – made from durable 300 Series Stainless Steel.
- *Easy to operate* – SmartTouch Touch Screen Controllers feature a large 7" VGA full color touch screen with easy to navigate tab menu. A library of various menu items are included for quick and easy preparation.
- *Unique Auto Comp™ feature* – automatically adjusts cooking time to accommodate for varying sizes and temperatures of loads.
- *Automatic cook cycle counter* – monitors production between filtering.
- *Built-in filter system* – provides quick, easy, and safe cooking oil filtration; no heated fittings to disconnect.
- *Temp-N-Time controller available.*

* Cooktime varies with weight of product.



Specifications

Primary construction is of stainless steel built on powder-coated steel frame with chrome-plated front leveling feet. Rear legs are fitted with casters.

Round cooking well with 21 pound cooking oil capacity operates between 12-14 psi gauge pressure at temperatures up to 375° F.

Triple-redundant safety system is featured consisting of chrome plated relief valve, stainless steel splash guard and single action patented cam lock cover system with pressure regulator interlock. Also has single action combined pressure regulator valve/remote timer control, drain valve interlock and pressure activated cover locking mechanism. All ensure operator convenience and safety.

SmartTouch Touch Screen controller provides a programmable library with preloaded menu items and an automatic cook-cycle counter. Auto-Comp feature automatically adjusts cooking time dependent on size and temperature of load. On-screen prompts assist users in operating and maintenance functions.

On-board integrated filtration system consists of easily accessible stainless steel filter tray assembly. Powered by a 1/3 horse-power motor coupled to 5 gallon-per-minute rotary gear displacement oil pump.

Equipment is covered by manufacturer's 1 year parts and labor warranty on all systems, additional 1 year on controller parts and 10 year repair warranty on cooking well.

Specifications subject to change without notice.

Broaster® Pressure Fryer – 1600

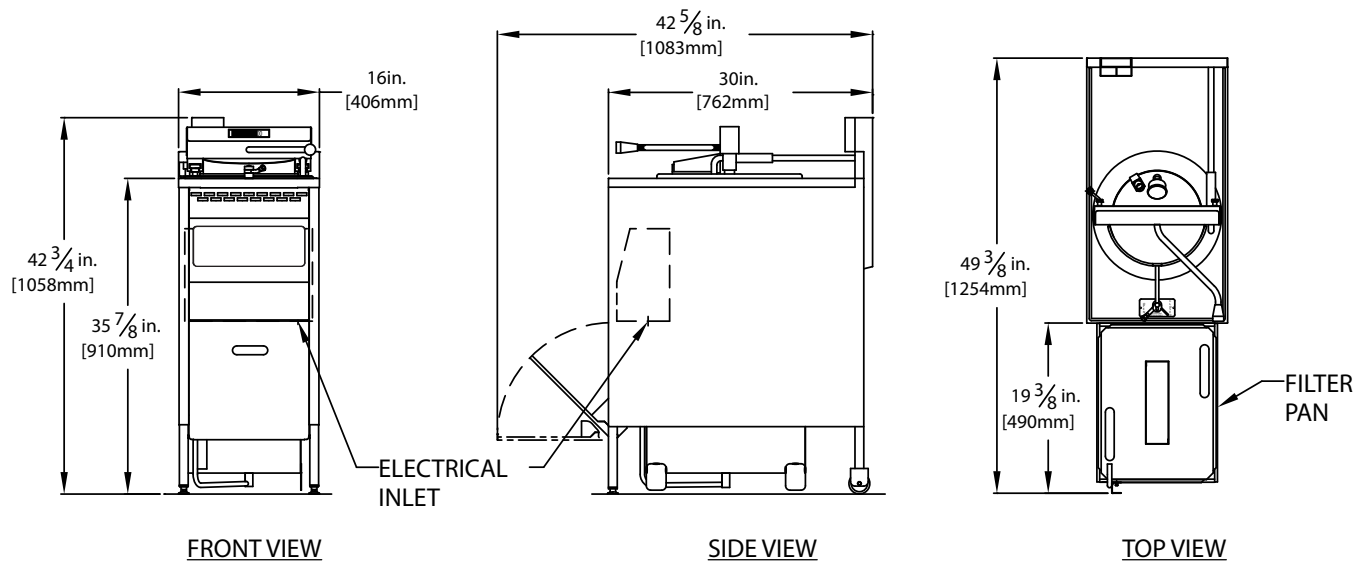

Dimensions

Model	Fresh Chicken Capacity	Cooking Oil Capacity	Operating Pressure	Overall Dimensions			Counter Height	Net/Ship Weight	Cubes
				W	D	H			
1600	7 lbs./load 40 lbs./hour	21 lbs.	12 - 14 P.S.I.	42 3/4"	42 5/8"	42-3/4"	35-7/8" (914 mm)	195/216 lbs.	16.53
				16"	29"	42-3/4"			
				(406 mm)	(737 mm)	(1088 mm)			

Energy Requirements

1600

6kW Rated Heating Elements

- 1 phase, 208 volt, 60 hz, 29 amps
- 1 phase, 240 volt, 60 hz, 25 amps
- 3 phase, 208 volt, 60 hz, 17 amps
- 3 phase, 240 volt, 60 hz, 15 amps

No cord/plug provided.

Additional Features

- Durable, welded, tubular steel frame is powder-coated to resist corrosion.
- Stainless steel top and side panels offer durability and easy cleaning.
- Unique stainless steel basket with a ratchet-style removable basket handle allows easier unloading of product.

Accessories & Options Available

- Basic Accessory Kit
- Complete Start-up Accessory Kit

Specifications subject to change without notice.

Broaster Company | 2855 Cranston Road, Beloit, WI 53511-3991 USA | 1.800.365.8278 | 1.608.365.0193 | broaster.com

Broaster®, Broasted®, Broaster Chicken®, Broaster Foods® and Broasterie® are registered trademarks of Broaster Company. Genuine Broaster Chicken® and Broaster Express® are also trademarks of Broaster Company. Use of Broaster Company trademarks is permitted ONLY by licensed trademark operators.